



50Ω TERMINATED 18 GHz SMA N/O S.P.8 T. SWITCH

OPTIONS:

R F CHARACTERISTICS

NUMBER OF WAYS : 8
 FREQUENCY RANGE : 0 - 18 GHz
 IMPEDANCE : 50 Ohms

FREQUENCY (GHz)	0 - 3	3 - 8	8 -12.4	12.4- 16	16 - 18
V.S.W.R <=	1.20	1.30	1.40	1.50	1.60
INSERT. LOSS <=	0.20 dB	0.30 dB	0.40 dB	0.55 dB	0.60 dB
ISOLATION >=	80 dB	70 dB	60 dB	60 dB	60 dB
AVER. POWER (*)	240 W	150 W	120 W	110 W	100 W

TERMINATION IMPEDANCE : 50 Ohms
 TERMINATION AVG. POWER AT 25° C : 1 W per termination
 3 W total power

ELECTRICAL CHARACTERISTICS

ACTUATOR : NORMALLY OPEN
 NOMINAL CURRENT AT 25° C (±10%) : 250 mA
 ACTUATOR VOLTAGE (Vcc) : 12V (10.2 to 13V) / NEGATIVE COMMON
 TERMINALS : 25 pins D-SUB male connector

MECHANICAL CHARACTERISTICS

CONNECTORS : SMA female per MIL-C 39012
 LIFE : 2.000.000 cycles per position
 SWITCHING TIME (nominal voltage;25° C) : < 15 ms
 CONSTRUCTION : splashproof
 WEIGHT : < 280 g

ENVIRONMENTAL CHARACTERISTICS

OPERATING TEMPERATURE RANGE (°C) : -40 , +85
 STORAGE TEMPERATURE RANGE (°C) : -55 , +85

(* : average power at 25° C per RF path)

This information is given as an indication. In the continual goal to improve our products, we reserve the right to make any modifications judged necessary

4112-9212

4113-9212 This information is given as an indication. In the continual goal to improve our products, we reserve the right to make any modifications judged necessary

DRAWING

General tolerance: ± 0,5 mm

R574 402805

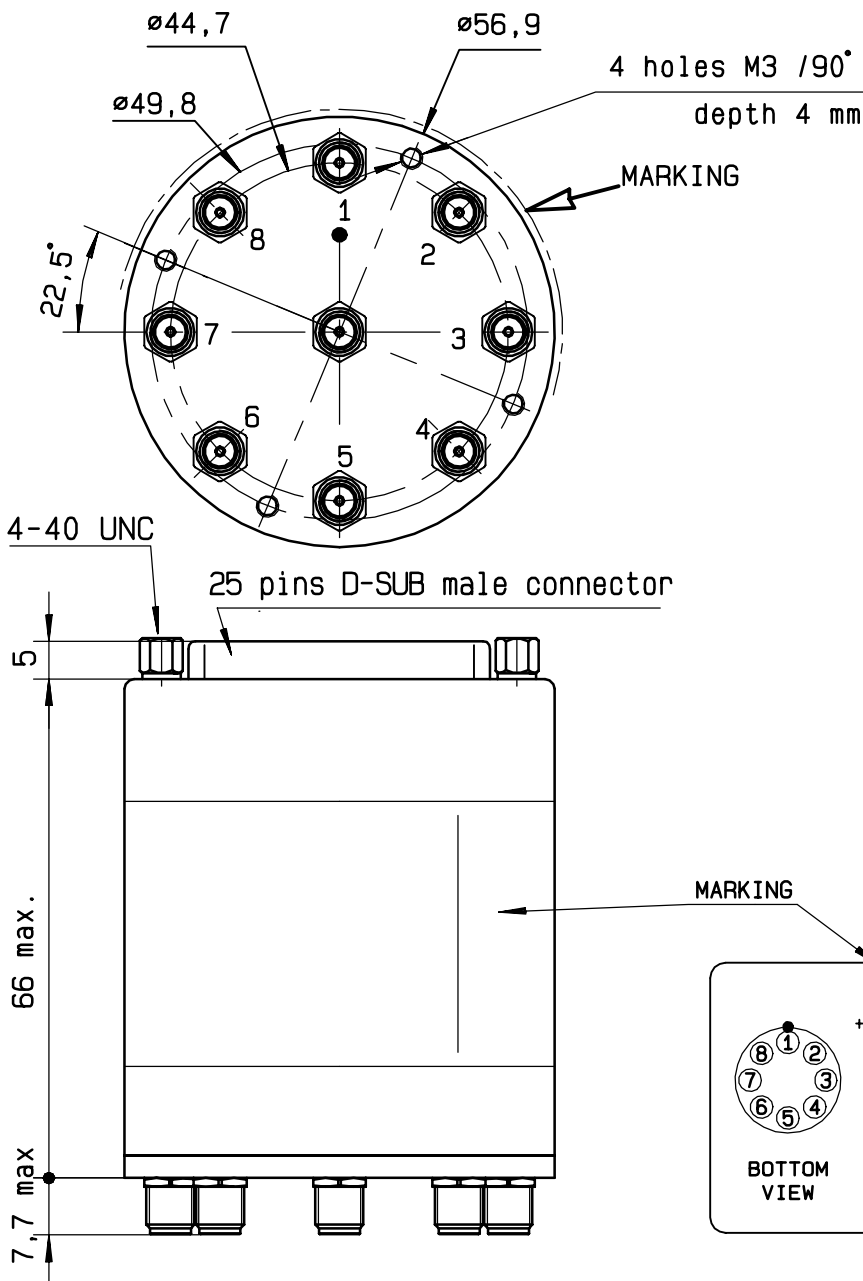

Voltage	RF continuity
-C +1	IN ↔ 1
-C +2	IN ↔ 2
-C +3	IN ↔ 3
-C +4	IN ↔ 4
-C +5	IN ↔ 5
-C +6	IN ↔ 6
-C +7	IN ↔ 7
-C +8	IN ↔ 8

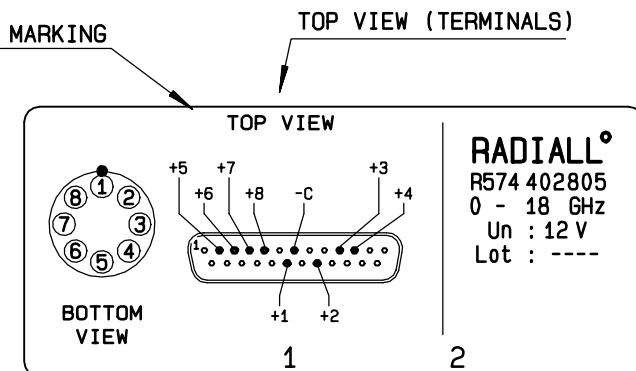

RADIALL^o
R574 402805
0 - 18 GHz
Un : 12 V
Lot : ----

SCHEMATIC DIAGRAM

